

SLIDE FIXTURE ASSEMBLY

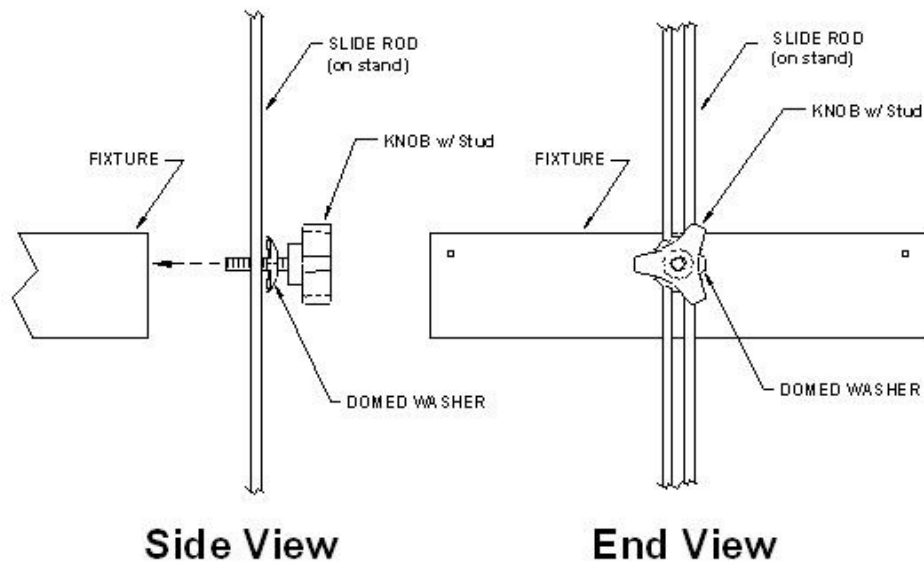

YG

1. Remove lamps before installing fixture.
2. Place one washer on the stud of the knob with indented side towards the slide rod. (side view diagram)
3. Hold one end of fixture near the slide rods. Put the stud between the slide rods and align to the hole in the fixture. Thread the knob into the fixture. Tighten knob **FIRMLY**. Repeat on other side.
4. Adjust fixture(s) to desired height and tighten knobs **SECURELY**. (Adjusting fixtures more than 6" per side may cause fixture to bend.)
5. Replace lamps, (make sure lamps are locked in place)

IMPORTANT Lamp Installation ALL FIXTURES ARE TESTED PRIOR TO SHIPPING

If the lamps are not properly installed in your fixture the following may result:

- ❖ The fixture may not fully light up, the lamps might **flicker** or **just glow**.
- ❖ The lamps will turn black on the ends.

Prior to calling to report a fixture will not work, we urge you to please test and make sure all lamps are properly installed and in working condition. Sometimes during shipping the filaments in the lamps will break, as a result the lamp itself will not light.

Rapid Start fluorescents must be seated in the sockets properly with the lamp base pins making good contact against the spring clips in the sockets. Although Rapid Start lamps may start if improperly seated, excessive end blackening and severely shortened lamp life will result.

How to be certain lamp is seated properly:

1. Each bipin lamp base has 2 small indentations - guide creases - 90° from each pin.
2. When the lamp is in the socket correctly, with the pins firmly seated in the spring clips, one guide crease will be visible centered directly in the socket opening.

